

Test ispravio: (1)
(2)

Ukupan broj bodova:

03. ožujka 2021. od 13:00 do 14:00

2021 Natjecanje iz informatike

Županijsko natjecanje / Osnove informatike
Srednje škole

Ime i prezime	
Škola	
Program (prirodoslovno-matematičke gimnazije, ostale gimnazije i strukovne škole)	
Razred	
Mentor	



Sadržaj

Upute za natjecatelje.....	1
Zadaci 1. – 11.	2
Zadaci 12. – 13.	6
Zadaci 14. – 24.	8

Upute za natjecatelje

Vrijeme pisanja: 60 minuta

Dragi natjecatelji,

test koji je pred vama sastoji se od 24 pitanja različitih vrsta i težine. Vrijeme rješavanja ograničeno je na 60 minuta, a najveći mogući broj bodova je 37.

Testu možete pristupiti samo jednom, pa pripazite da ga ne predate prije nego što ste upisali sve odgovore.

Za vrijeme rješavanja testa nije dozvoljeno koristiti mobitel, kalkulator, pametne satove niti programe instalirane na računalu. Na računalu je dozvoljeno pokrenuti samo jedan web preglednik u kojemu je otvorena samo kartica s testom. Prilikom rješavanja testa, nije dozvoljeno koristiti uvećanje ili smanjenje prikaza u pregledniku te osvježavati stranicu. U slučaju nepoštivanja pravila, možete biti diskvalificirani s natjecanja.

Dežurni nastavnik dat će vam lozinku za pristup testu i prazan papir koji možete koristiti za pomoć pri rješavanju zadataka.

Kada završite, pozovite dežurnog nastavnika da prepíše broj bodova s računalnog testa.

Nakon predaje testa moći ćete vidjeti samo broj bodova, dok će točni odgovori biti dostupni tek nakon zatvaranja testa.

Sretno svima

Tim za kategoriju Osnove informatike srednje škole

Zadaci 1. – 11.

U sljedećim zadacima među ponuđenim odgovorima zaokružite **JEDAN ili VIŠE** točnih odgovora.

Broj zadatka	Pitanje	Mogući bodovi
1.	<p>Što čini nedavno otkriven malware, mistično nazvan "Adrozek"?</p> <p>A. U tražilicu ubacuje lažne oglase. B. Prosljeđuje svaki primljeni email na servisu Gmail na specificiranu adresu. C. Onemogućuje rad ulaznih uređaja. D. Postupno briše podatke s korisnikova računala svakih 36 h. E. Instalira na računalo aplikaciju po želji.</p>	1
2.	<p>Tko je izumitelj World Wide Weba?</p> <p>A. Steve Jobs B. Tim Berners Lee C. Guido van Rossum D. Niklaus Wirth E. Bjarne Stroustrup F. Mark Zuckerberg G. Bill Gates H. Bill Rogers</p>	1
3.	<p>Edi je slučajno obrisao radni list u jednoj staroj Excel datoteci pod imenom zadaca.xlsx. Odmah je uvidio pogrešku pa je nazvao prijatelje i pitao kako može vratiti obrisani radni list.</p> <ul style="list-style-type: none"> • Tin mu je rekao da proba s CTRL+Z. • Teo je predložio da na alatnoj traci za brzi pristup klikne na strelicu u lijevo (Poništi). • Lota je rekla da izađe, bez spremanja, iz Excela i ponovno uđe. • Karlo je zaključio da ako je nakon brisanja spremio dokument, nema mogućnosti (bez vanjskih programa) vraćanja obrisanog radnog lista. <p>Tko je u pravu?</p> <p>A. Tin B. Teo C. Lota D. Karlo</p> <p>Pogrešan odgovor donosi negativne bodove</p>	1

Broj zadatka	Pitanje	Mogući bodovi
4.	<p>Što ćemo odabrati ako u programu za obradu teksta MS Word tri puta (brzo) kliknemo unutar teksta?</p> <p>A. Odlomak B. Riječ C. Cijelu stranicu D. Rečenicu</p>	1
5.	<p>Kojom kombinacijom tipki u MS PowerPointu možemo ubaciti novi slajd u postojeću prezentaciju?</p> <p>A. Ctrl + O B. Ctrl + M C. Ctrl + N D. Ctrl + I E. Ctrl + F</p>	1
6.	<p>Famozni investitor Mislav odlučio se ubaciti na tržište kriptovaluta i to ulaganjem u Bitcoin. No, ne može uložiti u nešto što ne zna kako funkcionira, stoga vas pita pomoću koje tehnologije funkcionira Bitcoin? Ukoliko odgovorite točno obećao je dati vam 0.0001BTC (mi mu ne bismo vjerovali...).</p> <p>A. Vactrain B. Biometrija C. Ion drive D. Blockchain</p>	1
7.	<p>Kako se naziva mrežna struktura u kojoj računala mogu biti direktno povezana sa svim ostalim računalima u mreži?</p> <p>A. Zvezdasta B. Linearna C. Isprepletena D. Prstenasta</p>	1















Broj zadatka	Pitanje	Mogući bodovi															
8.	<p>Na satu informatike postavljen je zadatak: Zadan je segment prirodnih brojeva [a,b]. Treba odrediti koliko različitih brojeva je moguće dobiti zbrajajući po dva broja, ne nužno različita, iz zadanog segmenta. Edi, Adam, Tom i Lota riješili su zadatak, svatko na svoj način. Promotrite ih i odgovorite na pitanje!</p> <table border="1" data-bbox="363 517 1273 1317"> <thead> <tr> <th></th> <th>Python</th> <th>C</th> </tr> </thead> <tbody> <tr> <td>Edi</td> <td><pre>A=int(input()) B=int(input()) print(2*(B-A+1)-1)</pre></td> <td><pre>int A,B; int main() { scanf("%d",&A); scanf("%d",&B); printf("%d",2*(B-A+1)-1); return 0;}</pre></td> </tr> <tr> <td>Tom</td> <td><pre>A=int(input()) B=int(input()) print(2*(B -A+1))</pre></td> <td><pre>int A,B; int main() { scanf("%d",&A); scanf("%d",&B); printf("%d",2*(B-A+1)); return 0;}</pre></td> </tr> <tr> <td>Adam</td> <td><pre>A=int(input()) B=int(input()) b=B-A s=2*b-1 print(s)</pre></td> <td><pre>int A,B,b,s; int main() { scanf("%d",&A); scanf("%d",&B); b=B-A; s=2*b-1; printf("%d",s); return 0;}</pre></td> </tr> <tr> <td>Lota</td> <td><pre>A=int(input()) B=int(input()) b=B-A s=2*b+1 print(s)</pre></td> <td><pre>int A,B,b,s; int main() { scanf("%d",&A); scanf("%d",&B); b=B-A; s=2*b+1; printf("%d",s); return 0;}</pre></td> </tr> </tbody> </table> <p>Tko je točno riješio postavljeni zadatak?</p> <ul style="list-style-type: none"> A. Svi osim Toma B. Lota i Edi C. Svi osim Edija D. Samo Edi E. Adam i Tom F. Samo Lota G. Svi su točno riješili H. Lota i Adam I. Edi i Tom J. Samo Adam K. Samo Tom L. Lota i Tom M. Svi osim Lote N. Svi osim Adama O. Adam i Edi P. Nitko nije točno riješio 		Python	C	Edi	<pre>A=int(input()) B=int(input()) print(2*(B-A+1)-1)</pre>	<pre>int A,B; int main() { scanf("%d",&A); scanf("%d",&B); printf("%d",2*(B-A+1)-1); return 0;}</pre>	Tom	<pre>A=int(input()) B=int(input()) print(2*(B -A+1))</pre>	<pre>int A,B; int main() { scanf("%d",&A); scanf("%d",&B); printf("%d",2*(B-A+1)); return 0;}</pre>	Adam	<pre>A=int(input()) B=int(input()) b=B-A s=2*b-1 print(s)</pre>	<pre>int A,B,b,s; int main() { scanf("%d",&A); scanf("%d",&B); b=B-A; s=2*b-1; printf("%d",s); return 0;}</pre>	Lota	<pre>A=int(input()) B=int(input()) b=B-A s=2*b+1 print(s)</pre>	<pre>int A,B,b,s; int main() { scanf("%d",&A); scanf("%d",&B); b=B-A; s=2*b+1; printf("%d",s); return 0;}</pre>	2
	Python	C															
Edi	<pre>A=int(input()) B=int(input()) print(2*(B-A+1)-1)</pre>	<pre>int A,B; int main() { scanf("%d",&A); scanf("%d",&B); printf("%d",2*(B-A+1)-1); return 0;}</pre>															
Tom	<pre>A=int(input()) B=int(input()) print(2*(B -A+1))</pre>	<pre>int A,B; int main() { scanf("%d",&A); scanf("%d",&B); printf("%d",2*(B-A+1)); return 0;}</pre>															
Adam	<pre>A=int(input()) B=int(input()) b=B-A s=2*b-1 print(s)</pre>	<pre>int A,B,b,s; int main() { scanf("%d",&A); scanf("%d",&B); b=B-A; s=2*b-1; printf("%d",s); return 0;}</pre>															
Lota	<pre>A=int(input()) B=int(input()) b=B-A s=2*b+1 print(s)</pre>	<pre>int A,B,b,s; int main() { scanf("%d",&A); scanf("%d",&B); b=B-A; s=2*b+1; printf("%d",s); return 0;}</pre>															

Broj zadatka	Pitanje	Mogući bodovi
9.	<p>Pomoću kojeg konektora se grafička kartica spaja se na matičnu ploču?</p> <p>A. ARM B. SHADER C. PCI EXPRESS D. DVI E. SATA F. VRAM</p>	1
10.	<p>Koji je ispravan HTML tag za dodavanje boje pozadine?</p> <p>A. <code><body bg="yellow"></code> B. <code><background>yellow</background></code> C. <code><body <bg>="yellow" </bg>></code> D. <code><body style="background-color:yellow;"></code></p>	1
11.	<p>Koju metodu enkripcije koristi Secure Shell?</p> <p>A. FENIX B. AES C. SCTP D. ATM</p>	1

Zadaci 12. – 13.

U sljedećim zadacima ispravno spojite parove tako da na predviđeno mjesto, pored slova, upišete broj koji označava točan odgovor

Broj zadatka	Pitanje	Mogući bodovi																																		
12.	<p>Spoji preglednik i proizvođača.</p> <table border="1" data-bbox="268 734 1206 976"> <thead> <tr> <th colspan="2">Opis</th> </tr> </thead> <tbody> <tr> <td>A</td> <td>Chrome</td> </tr> <tr> <td>B</td> <td>Safari</td> </tr> <tr> <td>C</td> <td>Edge</td> </tr> <tr> <td>D</td> <td>Navigator</td> </tr> <tr> <td>E</td> <td>Firefox</td> </tr> </tbody> </table> <table border="1" data-bbox="675 1055 927 1296"> <thead> <tr> <th colspan="2">Naziv</th> </tr> </thead> <tbody> <tr> <td>1</td> <td>Google</td> </tr> <tr> <td>2</td> <td>Apple</td> </tr> <tr> <td>3</td> <td>Microsoft</td> </tr> <tr> <td>4</td> <td>Netscape</td> </tr> <tr> <td>5</td> <td>Mozilla</td> </tr> </tbody> </table> <table border="1" data-bbox="639 1429 963 1509"> <thead> <tr> <th>A</th> <th>B</th> <th>C</th> <th>D</th> <th>E</th> </tr> </thead> <tbody> <tr> <td> </td> <td> </td> <td> </td> <td> </td> <td> </td> </tr> </tbody> </table>	Opis		A	Chrome	B	Safari	C	Edge	D	Navigator	E	Firefox	Naziv		1	Google	2	Apple	3	Microsoft	4	Netscape	5	Mozilla	A	B	C	D	E						1
Opis																																				
A	Chrome																																			
B	Safari																																			
C	Edge																																			
D	Navigator																																			
E	Firefox																																			
Naziv																																				
1	Google																																			
2	Apple																																			
3	Microsoft																																			
4	Netscape																																			
5	Mozilla																																			
A	B	C	D	E																																

Broj zadatka	Pitanje	Mogući bodovi																																																																						
13.	<p>Poveži način predstavljanja (čuvanja) informacija sa slikom koja ju prikazuje.</p> <table border="1" data-bbox="272 443 863 1675"> <thead> <tr> <th colspan="2">Slika</th> </tr> </thead> <tbody> <tr> <td data-bbox="272 483 368 663">A</td> <td data-bbox="368 483 863 663">  </td> </tr> <tr> <td data-bbox="272 663 368 853">B</td> <td data-bbox="368 663 863 853">  </td> </tr> <tr> <td data-bbox="272 853 368 1014">C</td> <td data-bbox="368 853 863 1014">  <p>9 0123456789</p> </td> </tr> <tr> <td data-bbox="272 1014 368 1223">D</td> <td data-bbox="368 1014 863 1223"> <table border="1"> <tbody> <tr><td>1.</td><td>A</td><td>B</td><td>C</td><td>D</td><td>X</td></tr> <tr><td>2.</td><td>A</td><td>X</td><td>B</td><td>C</td><td>D</td></tr> <tr><td>3.</td><td>A</td><td>B</td><td>X</td><td>C</td><td>D</td></tr> <tr><td>4.</td><td>A</td><td>X</td><td>B</td><td>C</td><td>D</td></tr> <tr><td>5.</td><td>A</td><td>B</td><td>C</td><td>X</td><td>D</td></tr> </tbody> </table> </td> </tr> <tr> <td data-bbox="272 1223 368 1447">E</td> <td data-bbox="368 1223 863 1447">  </td> </tr> <tr> <td data-bbox="272 1447 368 1675">F</td> <td data-bbox="368 1447 863 1675">  </td> </tr> </tbody> </table> <table border="1" data-bbox="611 1756 994 1839"> <thead> <tr> <th>A</th> <th>B</th> <th>C</th> <th>D</th> <th>E</th> <th>F</th> </tr> </thead> <tbody> <tr> <td> </td> <td> </td> <td> </td> <td> </td> <td> </td> <td> </td> </tr> </tbody> </table>	Slika		A		B		C	 <p>9 0123456789</p>	D	<table border="1"> <tbody> <tr><td>1.</td><td>A</td><td>B</td><td>C</td><td>D</td><td>X</td></tr> <tr><td>2.</td><td>A</td><td>X</td><td>B</td><td>C</td><td>D</td></tr> <tr><td>3.</td><td>A</td><td>B</td><td>X</td><td>C</td><td>D</td></tr> <tr><td>4.</td><td>A</td><td>X</td><td>B</td><td>C</td><td>D</td></tr> <tr><td>5.</td><td>A</td><td>B</td><td>C</td><td>X</td><td>D</td></tr> </tbody> </table>	1.	A	B	C	D	X	2.	A	X	B	C	D	3.	A	B	X	C	D	4.	A	X	B	C	D	5.	A	B	C	X	D	E		F		A	B	C	D	E	F							<table border="1" data-bbox="930 763 1257 1122"> <thead> <tr> <th colspan="2">Dekadski zapis</th> </tr> </thead> <tbody> <tr> <td>1</td> <td>Magnetska traka</td> </tr> <tr> <td>2</td> <td>Čip</td> </tr> <tr> <td>3</td> <td>Bar kod</td> </tr> <tr> <td>4</td> <td>Optički čitljiv obrazac</td> </tr> <tr> <td>5</td> <td>MICR kod</td> </tr> <tr> <td>6</td> <td>QR kod</td> </tr> </tbody> </table> <p style="text-align: center;">1</p>	Dekadski zapis		1	Magnetska traka	2	Čip	3	Bar kod	4	Optički čitljiv obrazac	5	MICR kod	6	QR kod
Slika																																																																								
A																																																																								
B																																																																								
C	 <p>9 0123456789</p>																																																																							
D	<table border="1"> <tbody> <tr><td>1.</td><td>A</td><td>B</td><td>C</td><td>D</td><td>X</td></tr> <tr><td>2.</td><td>A</td><td>X</td><td>B</td><td>C</td><td>D</td></tr> <tr><td>3.</td><td>A</td><td>B</td><td>X</td><td>C</td><td>D</td></tr> <tr><td>4.</td><td>A</td><td>X</td><td>B</td><td>C</td><td>D</td></tr> <tr><td>5.</td><td>A</td><td>B</td><td>C</td><td>X</td><td>D</td></tr> </tbody> </table>	1.	A	B	C	D	X	2.	A	X	B	C	D	3.	A	B	X	C	D	4.	A	X	B	C	D	5.	A	B	C	X	D																																									
1.	A	B	C	D	X																																																																			
2.	A	X	B	C	D																																																																			
3.	A	B	X	C	D																																																																			
4.	A	X	B	C	D																																																																			
5.	A	B	C	X	D																																																																			
E																																																																								
F																																																																								
A	B	C	D	E	F																																																																			
Dekadski zapis																																																																								
1	Magnetska traka																																																																							
2	Čip																																																																							
3	Bar kod																																																																							
4	Optički čitljiv obrazac																																																																							
5	MICR kod																																																																							
6	QR kod																																																																							

Zadaci 14. – 24.

U sljedećim zadacima odgovarate kratkim odgovorom (riječ, broj, slovo,...). Odgovor upišite na predviđeno mjesto za odgovor. U računskim zadacima nije potrebno upisivati mjernu jedinicu ili oznaku baze

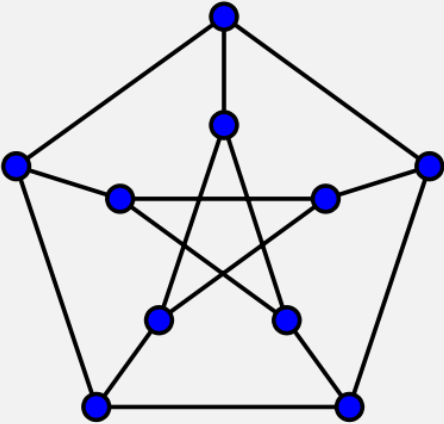
Broj zadatka	Pitanje	Mogući bodovi
14.	<p>U nekom ljepšem svemiru mali Vladimir i prof. double H. stigli su u Primošten. Vladimiru je ovo ispunjenje snova te se prisjetio zadatka koji mu je omogućio ovaj trenutak. Dok Vladimir uživa na plaži riješimo i mi taj zadatak kako bi mu se pridružili.</p> <p>Zadatak glasi: "Pikule su povezane na način prikazan na slici.</p>  <p>Želimo ubaciti pikule drugih boja, ali tako da ne postoje dvije povezane pikule iste boje. Kako svaka pikula nove boje zahtjeva kupnju novog paketa pikula zanima nas koliki je minimalan broj različitih boja da bi uvjet bio ispunjen?</p>	2
	Odgovor:	
15.	<p>Uporabom IEEE -754 standarda jednostruke preciznosti zapiši dekadski broj -13.625 u heksadekadskom obliku.</p>	1
	Odgovor:	

Broj zadatka	Pitanje	Mogući bodovi				
16.	Koliko nula ima u binarnom prikazu broja $16^n + 1$?	2				
Odgovor:						
17.	<p>Što će se ispisati nakon izvršavanja ovog dijela programa?</p> <table border="1" data-bbox="365 629 1038 1592"> <tr> <td data-bbox="368 633 555 1093">Python</td> <td data-bbox="558 633 1035 1093"> <pre>a=354612 b=0 i=1 m=1 while a: if i%2: b=b*10+a%10 else: m=m*10 b=m*(a%10)+b m=m*10 i=i+1 a=a//10 print(b)</pre> </td> </tr> <tr> <td data-bbox="368 1097 555 1588">C</td> <td data-bbox="558 1097 1035 1588"> <pre>int main() { int a=354612,b=0,i=1,m=1; while (a) { if(i%2) b=b*10+a%10; else {m=m*10; b=m*(a%10)+b; m=m*10;} i=i+1; a=a/10; } printf("%5d",b); return 0; }</pre> </td> </tr> </table>	Python	<pre>a=354612 b=0 i=1 m=1 while a: if i%2: b=b*10+a%10 else: m=m*10 b=m*(a%10)+b m=m*10 i=i+1 a=a//10 print(b)</pre>	C	<pre>int main() { int a=354612,b=0,i=1,m=1; while (a) { if(i%2) b=b*10+a%10; else {m=m*10; b=m*(a%10)+b; m=m*10;} i=i+1; a=a/10; } printf("%5d",b); return 0; }</pre>	2
Python	<pre>a=354612 b=0 i=1 m=1 while a: if i%2: b=b*10+a%10 else: m=m*10 b=m*(a%10)+b m=m*10 i=i+1 a=a//10 print(b)</pre>					
C	<pre>int main() { int a=354612,b=0,i=1,m=1; while (a) { if(i%2) b=b*10+a%10; else {m=m*10; b=m*(a%10)+b; m=m*10;} i=i+1; a=a/10; } printf("%5d",b); return 0; }</pre>					
Odgovor:						
18.	Odredi $X_{(2)}$ ako je: $\frac{X_{(2)}}{15_{(16)}} + \frac{93_{(16)}}{10101_{(2)}} = \frac{1111000_{(2)}}{10_{(10)}}$	2				
Odgovor:						

Broj zadatka	Pitanje	Mogući bodovi
19.	<p>Ako su realni brojevi u izrazu zapisani uporabom IEEE -754 standarda jednostruke preciznosti u heksadekadskom obliku, odredi vrijednost izraza:</p> $\frac{C4FA4000}{C2FA4000} \cdot 3E000000 =$ <p>Rezultat zapiši kao dekadski broj.</p>	2
Odgovor:		
20.	<p>Vrijednosti logičkih izraza A., B., C., D., i E poredaj prema broju jedinica koje imaju na izlazu.</p> <p>Napomena: Na prvom mjestu treba biti izraz koji ima najmanje jedinica na izlazu, a na posljednjem izraz koji ima najveći broj jedinica na izlazu.</p> <div style="border: 1px solid black; padding: 10px; margin: 10px 0;"> <p>A. $A \cdot C + B \cdot \bar{C}$</p> <p>B. $A \cdot B \cdot \bar{C}$</p> <p>C. $(A + B) \cdot \bar{C}$</p> <p>D. $\bar{A} \cdot \bar{B} + C$</p> <p>E. $\bar{A} + \bar{B} + C$</p> </div>	2
Odgovor:		

Broj zadatka	Pitanje	Mogući bodovi																																				
21.	<p>U programu MS Excel imamo ovu tablicu:</p> <table border="1"> <thead> <tr> <th></th> <th>A</th> <th>B</th> <th>C</th> </tr> </thead> <tbody> <tr> <td>1</td> <td>Učenik</td> <td>Ostvareni bodovi</td> <td>Ocjena</td> </tr> <tr> <td>2</td> <td>Prvi Prvić</td> <td>95</td> <td></td> </tr> <tr> <td>3</td> <td>Drugi Drugić</td> <td>63</td> <td></td> </tr> <tr> <td>4</td> <td>Treći Trečić</td> <td>25</td> <td></td> </tr> <tr> <td>5</td> <td>Četvrti Četvrtić</td> <td>54</td> <td></td> </tr> <tr> <td>6</td> <td>Peti Petić</td> <td>80</td> <td></td> </tr> <tr> <td>7</td> <td></td> <td></td> <td></td> </tr> <tr> <td>8</td> <td></td> <td></td> <td></td> </tr> </tbody> </table> <p>a) Koja vrijednost će pisati u ćeliji C2 ukoliko u nju upišemo formulu: =IF(B2>90;5;IF(B2>75;4;IF(B2>60;3;IF(B2>45;2;1))))</p> <p>b) Ako formulu iz ćelije C2 kopiramo u ćelije C3, C4, C5,C6 koje vrijednosti će one imati?</p> <p>c) Koja vrijednost će pisati u ćeliji C7 ukoliko u nju upišemo ovu formulu: =AVERAGE(C2:C6)</p>		A	B	C	1	Učenik	Ostvareni bodovi	Ocjena	2	Prvi Prvić	95		3	Drugi Drugić	63		4	Treći Trečić	25		5	Četvrti Četvrtić	54		6	Peti Petić	80		7				8				3
	A	B	C																																			
1	Učenik	Ostvareni bodovi	Ocjena																																			
2	Prvi Prvić	95																																				
3	Drugi Drugić	63																																				
4	Treći Trečić	25																																				
5	Četvrti Četvrtić	54																																				
6	Peti Petić	80																																				
7																																						
8																																						
<p>Odgovor: a) C2 = _____</p> <p>b) C3 = ____ C4 = ____ C5 = ____ C6 = ____</p> <p>c) C7 = _____</p>																																						

Broj zadatka	Pitanje	Mogući bodovi
22.	<p>Karlo je odlučio potražiti honorarni posao u jednoj informatičkoj firmi kako bi podebljao studentski budžet. Nakon obavljenog testiranja i razgovora saznao je da je primljen. Još pod dojmom sretne vijesti, pitao je stidljivo, do kojeg datuma u mjesecu može očekivati isplatu za obavljeni posao jer je saznao da će početkom idućeg mjeseca na akciji biti njegova omiljena čokolada s rižom (ona „prva na svijetu“).</p> <p>Na upit, Karlo je dobio sljedeći odgovor: „Idući mjesec, dan isplate je jednak broju jedinica u prikazu broja -39 u memoriji računala“. Karlo se zahvalio na odgovoru, međutim kad je htio odrediti dan isplate shvatio je da mu nije rečeno kojom metodom treba rečeni broj prikazati u memoriji računala.</p> <p>a) Broj jedinica u prikazu broja -39 metodom predznaka i apsolutne vrijednosti je:</p> <p>b) Broj jedinica u prikazu broja -39 metodom dvojnog komplementa je:</p>	2
<p>Odgovor:</p> <p>a) _____ b) _____</p>		

Broj zadatka	Pitanje	Mogući bodovi				
23.	<p>a) Što će se ispisati nakon izvršavanja ovog dijela programa?</p> <table border="1" data-bbox="363 398 1002 1332"> <tr> <td data-bbox="370 407 550 862">Python</td> <td data-bbox="557 407 995 862"> <pre>x=4 y=3 z=2 w=1 if x+y+z-w > x+y-z+w: x=x+y+z-w y=x + y - z + w if x-y+z+w< -x+y+z*w: z=x-y+z+w w=-x+y+z*w if -x-y+z+w< -x+y+z-w: x=x+y-z*w w= -x+y+z+w print(x+y+z+w)</pre> </td> </tr> <tr> <td data-bbox="370 871 550 1323">C</td> <td data-bbox="557 871 995 1323"> <pre>int main() { int x=4,y=3,z=2,w=1; if (x+y+z-w > x+y-z+w) {x=x+y+z-w; y=x + y - z + w;} if (x-y+z+w< -x+y+z*w) {z=x-y+z+w; w=-x+y+z*w;} if (-x-y+z+w< -x+y+z-w) {x=x+y-z*w; w= -x+y+z+w;} printf ("%d",x+y+z+w); return 0; }</pre> </td> </tr> </table> <p>b) Koja varijabla ima najveću vrijednost?</p>	Python	<pre>x=4 y=3 z=2 w=1 if x+y+z-w > x+y-z+w: x=x+y+z-w y=x + y - z + w if x-y+z+w< -x+y+z*w: z=x-y+z+w w=-x+y+z*w if -x-y+z+w< -x+y+z-w: x=x+y-z*w w= -x+y+z+w print(x+y+z+w)</pre>	C	<pre>int main() { int x=4,y=3,z=2,w=1; if (x+y+z-w > x+y-z+w) {x=x+y+z-w; y=x + y - z + w;} if (x-y+z+w< -x+y+z*w) {z=x-y+z+w; w=-x+y+z*w;} if (-x-y+z+w< -x+y+z-w) {x=x+y-z*w; w= -x+y+z+w;} printf ("%d",x+y+z+w); return 0; }</pre>	2 + 1
Python	<pre>x=4 y=3 z=2 w=1 if x+y+z-w > x+y-z+w: x=x+y+z-w y=x + y - z + w if x-y+z+w< -x+y+z*w: z=x-y+z+w w=-x+y+z*w if -x-y+z+w< -x+y+z-w: x=x+y-z*w w= -x+y+z+w print(x+y+z+w)</pre>					
C	<pre>int main() { int x=4,y=3,z=2,w=1; if (x+y+z-w > x+y-z+w) {x=x+y+z-w; y=x + y - z + w;} if (x-y+z+w< -x+y+z*w) {z=x-y+z+w; w=-x+y+z*w;} if (-x-y+z+w< -x+y+z-w) {x=x+y-z*w; w= -x+y+z+w;} printf ("%d",x+y+z+w); return 0; }</pre>					
<p>Odgovor: a) _____ b) _____</p>						

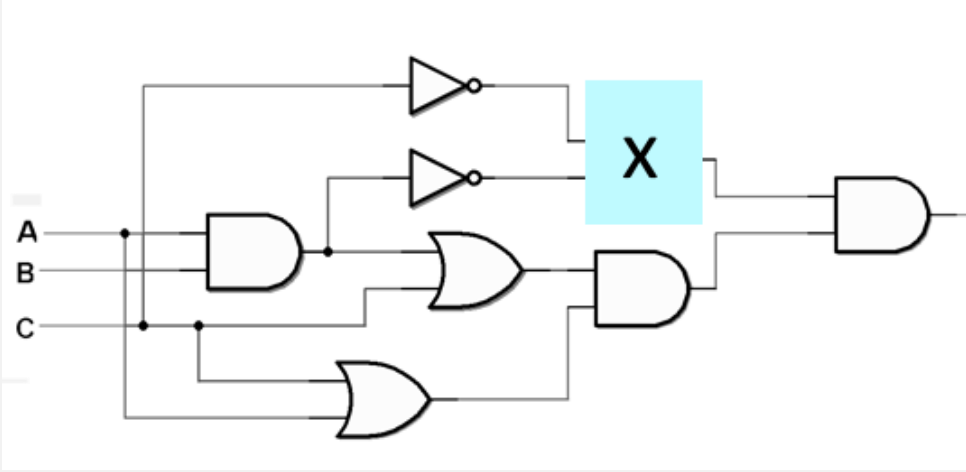
Broj zadatka	Pitanje	Mogući bodovi
24.	<p>Zadan je logički sklop:</p>  <p>a) Koji sklop (AND, OR, NAND ili NOR) treba staviti na mjesto logičkog sklopa X kako bi cijeli izraz imao na kraju jednak broj jedinica i nula</p> <p>b) Koji sklop (AND, OR, NAND ili NOR) treba staviti na mjesto logičkog sklopa X kako bi cijeli izraz bio kontradikcija</p>	2
<p>Odgovor:</p> <p>a) _____</p> <p>b) _____</p>		



Papir je namjerno ostavljen prazan za rješavanje zadataka

